

ACm/AC

Elettropompe centrifughe monogiranti *Centrifugal pumps*

Applicazione

- Possono essere utilizzate per trasferire acqua pulita o liquidi chimicamente non aggressivi. Sono utilizzabili per applicazioni domestiche ed industriali, irrigazione giardini, trasferimento d'acqua su medie distanze, sistemi di condizionamento e di refrigerazione, in vari campi industriali

Application

- It can be used to transfer clean water or other liquids similar to water in physical and chemical properties. It is suitable in industrial and urban water supply, for small living water supply, pressure boosting for high buildings and fire fighting, garden irrigation, long-distance water transfer, heating ventilation and air controlling, circulation and pressure boosting for cold and hot water, and supporting equipment etc.



POMPA

- Corpo pompa in ghisa
- Girante in acciaio inox aisi 304
- Albero AISI 304
- Temperatura max. liquido: +60°C
- Altezza di aspirazione manometrica fino a: 8mt

PUMP

- Cast iron pump body, support under special anti-rust treatment.
- Stainless steel impeller.
- AISI 304 shaft.
- Max. liquid temperature: +60° C
- Max. Suct: 8 m

MOTORE

- Motore monofase con protezione termica inserita nell'avvolgimento.
- Isolamento: classe F
- Classe di protezione: IP 44
- Temperatura ambiente massima: +40°C

MOTOR

- Motor with copper winding
- Single phase motor with built-in thermal protective device (auto protection & reset)
- Insulation class: F
- Protection class: IP44
- Max. ambient temperature: +40° C

Codici identificativi

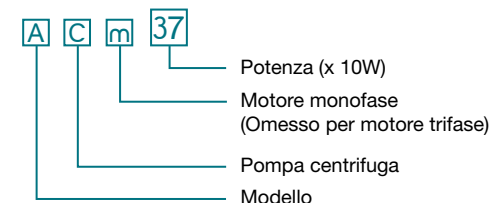

Identification Codes

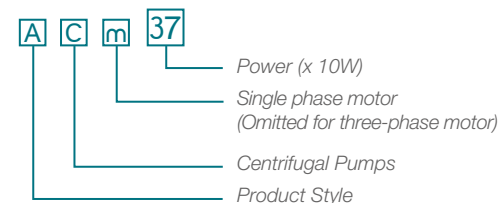

Dati tecnici | Technical Data

Modello Model	Potenza Power	Qm³/h	0	0.6	1.2	1.8	2.4	3.0	3.6	4.2	4.8	5.4	6.0	6.6	7.2	7.8	8.4	Codice Code	€ cad € each	
Monofase Single Phase	kW	HP	QL/min	0	10	20	30	40	50	60	70	80	90	100	110	120	130	140		
ACm37	0.37	0.5	H (mt)	22	21.5	21	20.5	19.5	18	17	15.5	14	12						10ACM37	128,00
ACm75	0.75	1.0		35	34.5	33.5	33	32	31	29	27	24	20	16					10ACM75	178,00
ACm110	1.1	1.5		40	39	38.5	38	37	36	34.5	33	31.5	29	26	23				10ACM110	272,00
ACm150	1.5	2		48	-	-	45.5	44.5	43.5	42.5	41.5	40.5	39	37	34.5	31	27	22	10ACM150	370,00
Trifase Three Phase																				
AC110	1.1	1.5	H (mt)	40	39	38.5	38	37	36	34.5	33	31.5	29	26	23				10AC110	277,00
AC150	1.5	2		48	-	-	45.5	44.5	43.5	42.5	41.5	40.5	39	37	34.5	31	27	22	10AC150	375,00

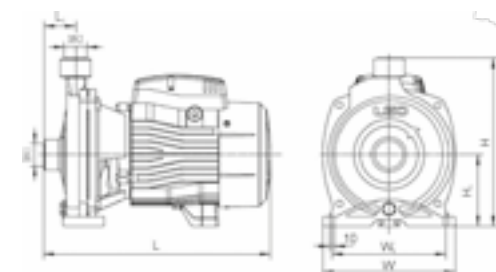

Dimensioni | Dimension

Modello Model	DN1	DN2	L (mm)	W (mm)	H (mm)	L ₁ (mm)	W ₁ (mm)	H ₁ (mm)
ACm37	1"	1"	270	157	216	42	122	90
ACm75	1"	1"	298	190	240	44	160	100
ACm110	1 1/4"	1"	353	206	263	50	178	112
AC110	1 1/4"	1"	353	206	263	50	178	112
ACm150	1 1/4"	1"	360	240	286	51	207	115
AC150	1 1/4"	1"	360	240	286	51	207	115

Diagramma prestazioni Hydraulic Performance Curve

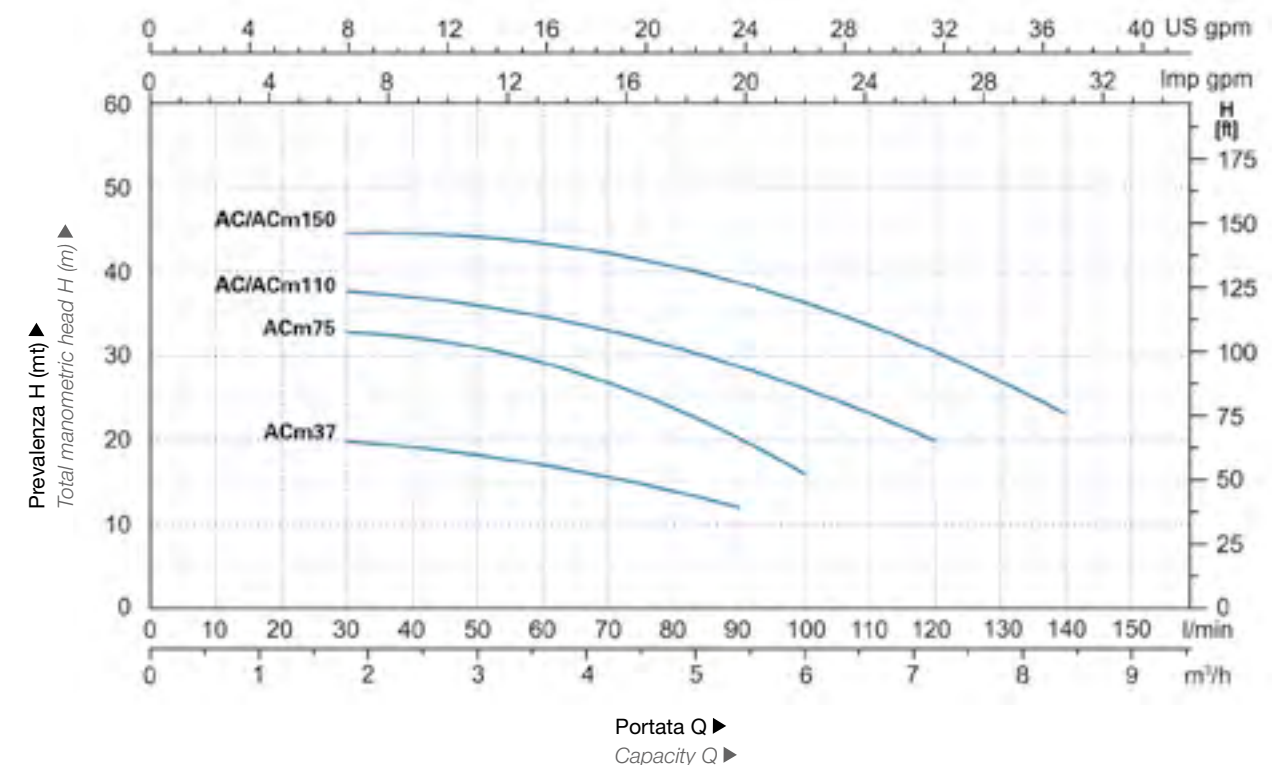

Descrizione componenti | Materials Table

Pos. Pos.	Part. Part.
1	Corpo pompa Pump body
2	Girante Impeller
3	O-ring O-ring
4	Tenuta meccanica Mechanical seal
5	Inserto Bracker cover
6	Supporto motore Support
7	Morsetteria Terminal board
8	Cassa motore con statore avvolto Stator
9	Copri morsetteria Capacitor box
10	Condensatore Capacitor
11	Albero motore Rotor
12	Cuscinetto Bearing
13	Scudo End cover
14	Ventola Fan
15	Copriventola Fan cover

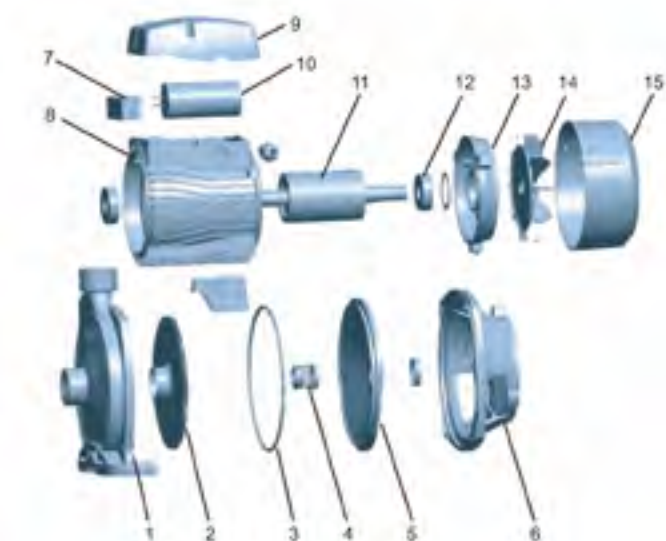

Dimensioni imballo | Package information

Modello Model	GW (Kg)	L (mm)	W (mm)	H (mm)
ACm37	8	287	180	230
ACm75	12.7	325	210	270
ACm110	17.8	383	233	287
AC110	17.8	383	233	287
ACm150	22.8	425	265	310
AC150	22.8	425	265	310

